

Warewashing
Small Single Skin GW, drain pump,
detergent & rinse aid dispenser, cold
rinse, 30b/h

ITEM # _____

MODEL # _____

NAME # _____

SIS # _____

AIA # _____

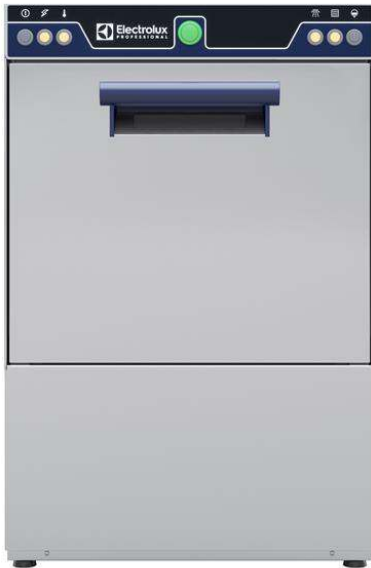
402292 (ESGU)

Glasswasher (small), with single skin, built-in drain pump, detergent and rinse aid dispenser and cold rinse, 1 cycle, 30b/h

Short Form Specification

Item No. _____

Unit shall be Glasswasher type hot water rinsing using rack dimension of 400*400mm. Electrical characteristics to be 230 volts single phase 50Hz operation with one wash cycle of 120 seconds. Washing performance is ensured by a powerful wash pump and revolving washing spray arm on bottom. Upper rinsing and lower integrated washing & rinsing arms in composite material. Rinse temperature and pressure guaranteed by built in pressure boiler. Cold rinse after the hot rinse cycle provides hygiene glasses, cool enough to handle. Double skinned counter-balance door. Large door opening of 290mm for washing tall glasses. Single skinned cabinet. Welded washing tank with round corners. 304 stainless steel construction to include door & frame. The unit shall include drain pump, detergent and rinse aid dispenser pumps and is equipped with electric cable with Schuko plug.

Main Features

- Built-in rinse aid dispenser with automatic initial and continuous cycle loading for perfect result while minimizing service and maintenance needs.
- 120 seconds cycle.
- Built-in pressure boiler designed to raise incoming water to a guaranteed minimum temperature of 82° C for sanitizing rinse. No external boiler is required.
- Maximum capacity of 30 racks per hour.
- Equipped with single phase electrical cable and Schuko plug for easy and fast installation.
- Easy service access to main components without moving the unit.
- Equipped with drain pump for easy and quick installation without opening the machine.
- Extra program to cold rinse beer and wine glasses providing sanitized glasses, cool enough to handle.
- Washing system endowed with rotating washing arms, high powered wash pump and large capacity wash tank for professional washing.
- Welded wash tank, sloped towards the drain, provides fast drainage in only a few minutes and guarantee a water tight solution.

Construction

- Completely closed on the back by a cover plate.
- Internal components (arms and filter) are easy extractable.
- Unit to feature rinse aid and detergent dispenser pumps.
- Robust structure thanks to stainless steel construction.

Sustainability

- Insulated double skin door construction preserves heat inside the tank to lower energy consumption and the noise. Counter-balance mechanism minimizes impact when opening and closing.
- Finished in top quality materials to ensure durability.
- Simple operation control panel.

APPROVAL: _____



Included Accessories

- 1 of Square basket for glasses 400x400x150mm PNC 864470
- 1 of Insert for 12 saucers, 290X90x75mm PNC 867048
- 1 of Square cutlery container, 89x113x113mm PNC 867049

Optional Accessories

- Square basket for glasses, 400x400x1100mm PNC 867039
- Inclination insert for glasses, 400x180mm PNC 867044
- Round basket for glasses, 400x180mm PNC 867047
- Inclination insert for glasses 400x400 mm PNC 867069
- Kit detergent dispenser for Single Skin XS and Single Skin S Glasswasher PNC 867072



Front

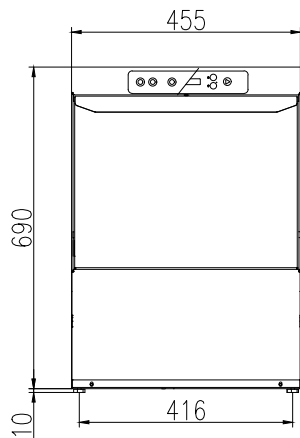

Side

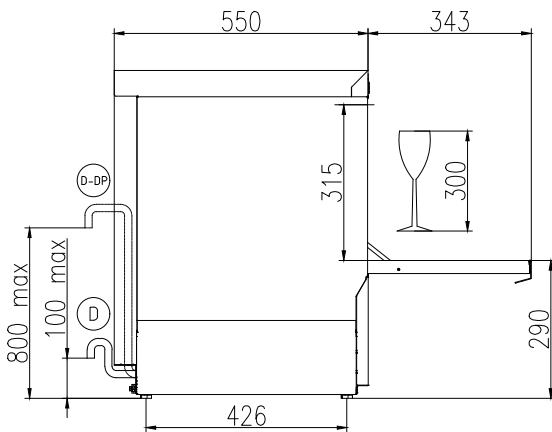

CWII = Cold Water inlet 1 (cleaning)
 D = Drain
 EI = Electrical inlet (power)
 EO = Electrical Outlet
 WI = Water inlet
 XD = Detergent connection

XR = Rinse aid connection

Rear side

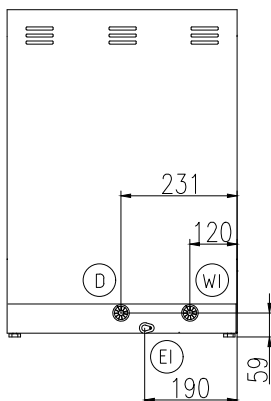

Electric

Supply voltage:	
402292 (ESGU)	220-240 V/1 ph/50 Hz
Default Installed Power:	2.7 kW
Boiler heating elements:	2.7 kW
Tank heating elements:	2.4 kW
Wash pump size:	0.2 kW

Water:

Pressure, bar min/max:	2-5 bar
Drain line size:	29mm
Washing tank capacity (lt):	12
Boiler Capacity (lt):	3
Incoming water line size:	3/4"

Key Information:

Baskets per hour*:	30
Working cycles time (sec.):	120
Wash temperature:	60°C
Cell dimensions - width:	405 mm
Cell dimensions - depth:	437 mm
Cell dimensions - height:	315 mm
Rinse temperature:	85 °C
External dimensions, Width:	455 mm
External dimensions, Depth:	550 mm
External dimensions, Height:	700 mm
Net weight:	39 kg
Shipping weight:	42 kg
Shipping height:	850 mm
Shipping width:	540 mm
Shipping depth:	630 mm
Shipping volume:	0.29 m ³

Sustainability

Water supply temperature*:	10-50 °C
Water consumption per cycle (lt):	2
Noise level:	61 dBA